

Marine Engine- WD10 Series

General Specifications

Bore & Stroke	126x130 mm
Displacement	9.7 L
Cylinder Number	6
Compression ratio	17:1
Fuel System	Mechanical Pump
Aspiration	T/TA
Emission Standard	IMO Tier II



Duty	Model	HP	kW	RPM
P1	WD10C190-15	190	140	1500
P1	WD10C218-15	218	160	1500
P1	WD10C240-15	240	176	1500
P1	WD10C258-15	258	190	1500
P1	WD10C278-15	278	205	1500
P1	WD10C190-18	190	140	1800
P1	WD10C200-18	200	147	1800

Duty	Model	HP	kW	RPM
P1	WD10C240-18	240	176	1800
P1	WD10C278-18	278	205	1800
P1	WD10C312-18	312	230	1800
P1	WD10C200-21	200	147	2100
P1	WD10C278-21	278	205	2100
P1	WD10C300-21	300	220	2100
P1	WD10C326-21	326	240	2100

Standard Equipments

Engine and block

- Cast iron frame style body structure
- One-piece forged crankshaft
- Separate cast iron cylinder heads and dry liners
- Aluminium alloy pistons with gallery oil cooling

Cooling system

- Fresh / raw water heat exchanger with integrated thermostatic valves and expansion tank
- Cast iron centrifugal fresh water pump, mechanically driven
- Self-priming raw water pump, mechanically driven

Lubrication system

- Full flow duplex type oil filters replaceable engine running
- Fresh water cooled lube oil cooler plate type

Fuel system

- P type in line injection pump
- Dual-skinned fuel pipe with alarm and leakage collector
- Duplex fuel filters replaceable engine running
- Water separated filter

Intake air and exhaust system

- Washable air filter & exhaust expansion joint
- Insulated dry type or water jacket exhaust manifold

Electrical system

- 24V electric starter motor and battery charging alternator
- Voyage safeguard monitor and 5m harness

Flywheel and housing

- SAE1 flywheel housing and SAE 14 flywheel

Certification

- CCS and EIAPP

Optional Equipments

- Different harness length of remote monitor
- Free end PTO

- Equipment and factory trial according to Major Classification Societies rules

	P1 Duty	P2 Duty	P3 Duty	P4 Duty
Application	Unrestricted continuous	continuous	intermittent	high performance
Engine load variations	Very little or none	continuous	important	very important
Mean engine load factor	80 to 100%	30 to 80%	50%	30%
Annual working time	More than 5000 h	3000 to 5000 h	1000 to 3000h	less than 1000 h
Time at full load	unlimited	8 h each 12 h	2 h each 12 h	1 h each 12 h

Dimensions and Weight

Length	1895mm
Width	948mm
Height	1176mm
Weight	1056kg

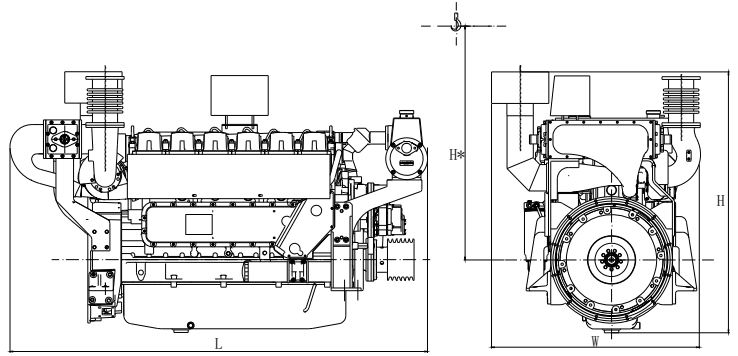

Power definition

Standard ISO 3046/1 -1995(F)

Reference conditions

Ambient temperature	25 °C
Barometric pressure	100 kPa
Relative humidity	30%
Raw water temperature	25 °C

Fuel

Relative density	0,840 ± 0,005
Lower calorific power	42 700 kJ/kg
Consumption tolerances	± 5 %

Lube oil

Recommend grade CF-4 15W/40

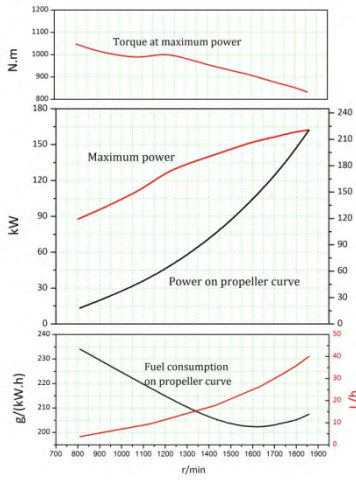

WD10C200-18

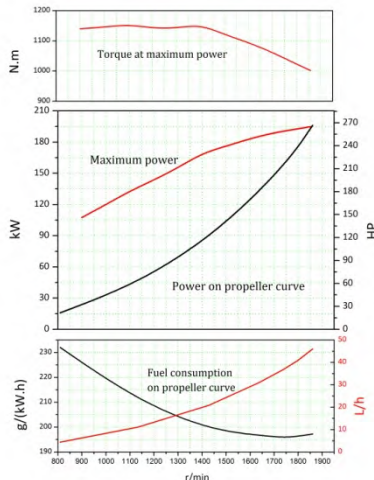

WD10C240-18

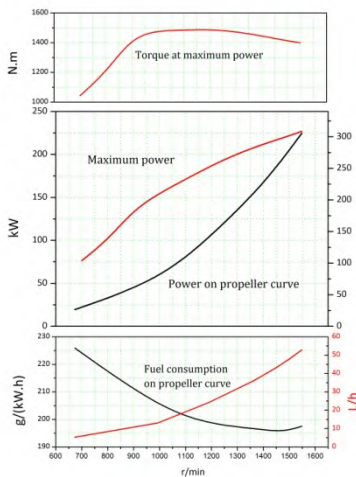

WD10C278-15

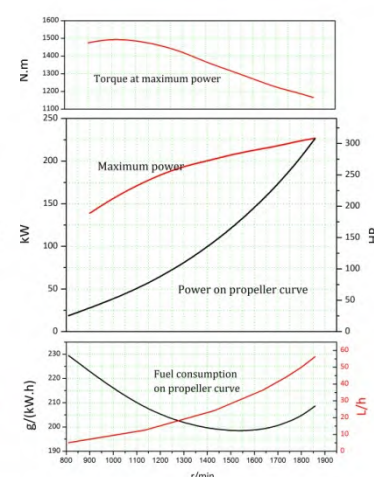

WD10C278-18

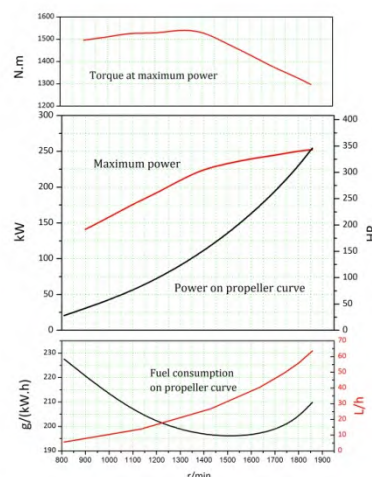

WD10C312-18

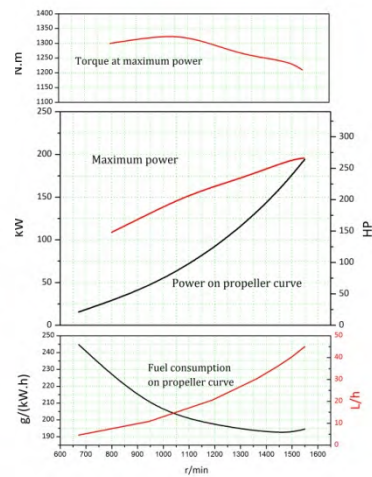

WD10C240-15

Distributed By:

Manufacturer: Weichai Power Co., Ltd
 Address: 197 A, Fushou East Street, High-Tech
 Development Zone, Weifang, China
www.weichai.com



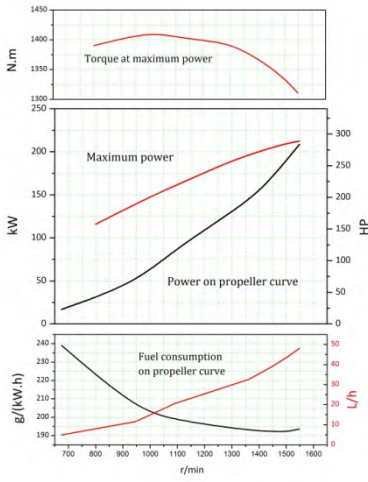

WP10C258-15

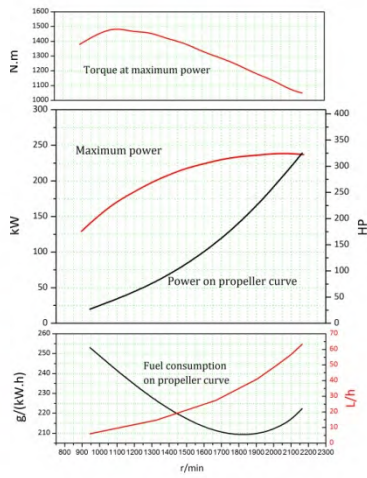

WP10C300-21

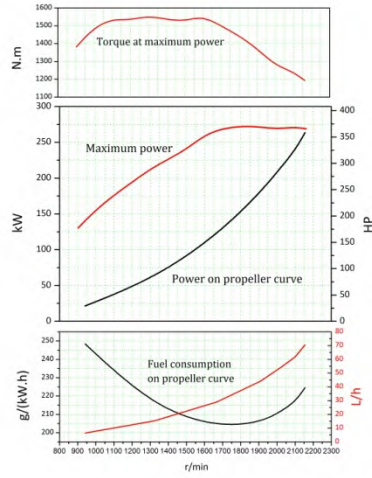

WP10C326-21

Distributed By:

Manufacturer: Weichai Power Co., Ltd
 Address: 197 A, Fushou East Street, High-Tech
 Development Zone, Weifang, China
www.weichai.com

